

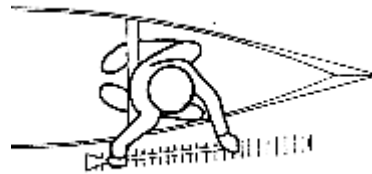

Pocono Plateau

Camp + Retreat Center

Canoeing Basics



Bow Stroke - This stroke is used to move the canoe forwards in a straight line. The stroke itself is simple. The paddler reaches forwards and places the paddle in the water. The paddle is then drawn towards the stern, in a line parallel to the keel. To recover the paddle is lifted from the water and swung forward in a circular motion. If done in reverse, this will propel the canoe backwards.

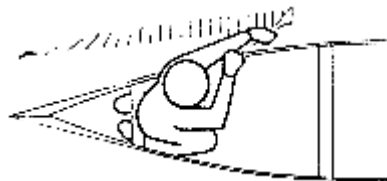

Canadian Stroke - If the bow and stern men both do the bow stroke the canoe will turn slowly due to the leverage created by the paddlers. To correct for this the sternman uses the Canadian stroke. This is essentially the same as the bow stroke, except the blade is pushed slightly away from the side of the canoe at the end of the stroke. This counteracts the leverage created by paddling. The sternman will need to use the Canadian stroke once for every three to four bow strokes in order to maintain a straight course.

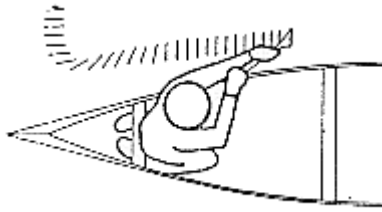

J-Stroke - This is a more severe form of the Canadian stroke, which is used by the sternman to turn the canoe towards the side that the sternman is paddling on.

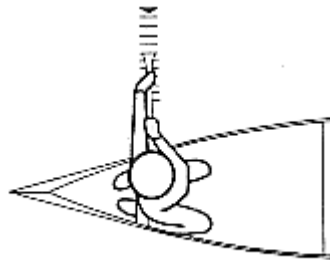

Draw - This stroke is done by extending the paddle outwards, and drawing towards yourself. If this is done on opposite sides of the canoe by both the paddlers the canoe will rotate rapidly. If this is done on the same side by both paddlers the canoe will move sideways

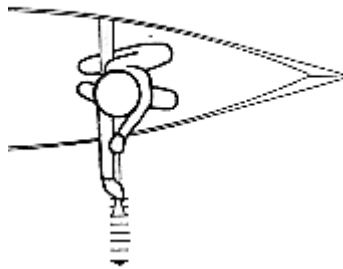

Pry/Push away - This is the opposite of the draw. The paddle is inserted into the water by the canoe, and pushed outwards. This has the same effect as the draw, but the result will be in the opposite direction.

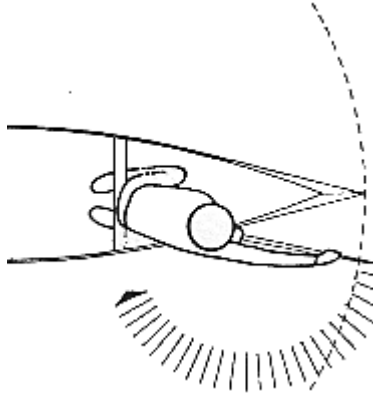

Sweep - This stroke turns the canoe in a circle away from the paddling side of the canoe. To do this stroke place the paddle in the water as far in front of you as you can. Pull the blade in a wide semicircle until the paddle is behind you. This can also be done in the reverse direction, which will rotate the canoe towards the paddling side.

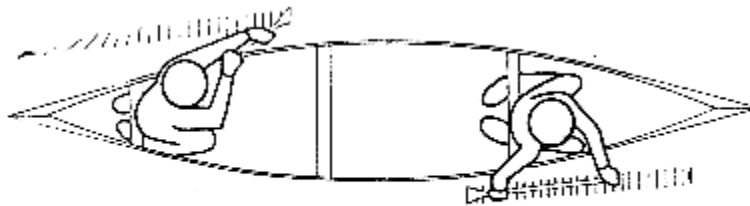

Going Straight - To go in a straight line the bowman should use the bow stroke, and the sternman should use the bow stroke, with enough Canadian strokes mixed in to keep the canoe traveling in a straight line

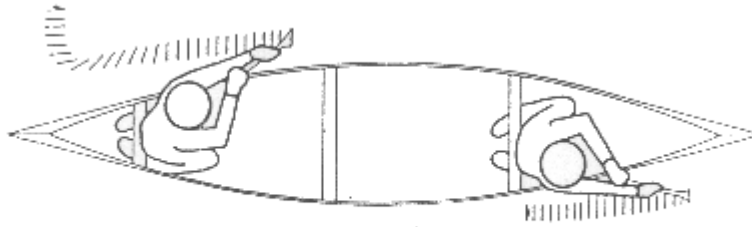

Medium Turns - To make a medium turn sternman can use a 'J' stroke on the appropriate side of the canoe, while the bowman maintains the bow stroke. The sternman can also use short draws and pry's to make medium turns.

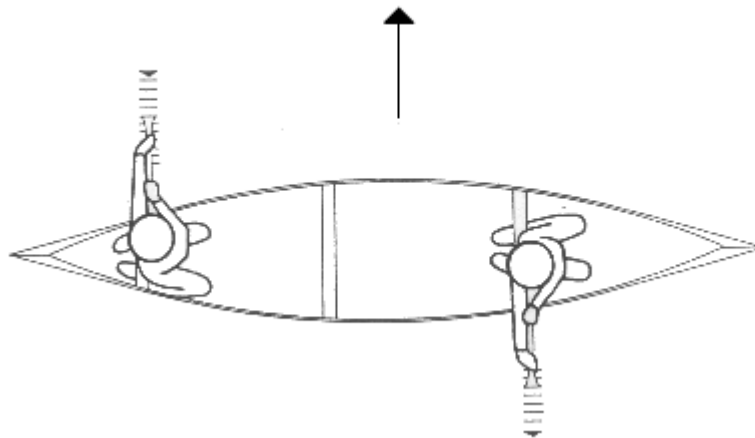

Moving Sideways - There are three ways to move a canoe sideways. The first is for both paddlers to use a draw on the same side of the canoe. This will draw the canoe towards the paddling side. This is good for moving sideways towards an object. The second method involves both paddlers using pry's on the same side of the canoe. Controlling the canoe is difficult when doing this, but it is good for bringing the canoe alongside a dock or another canoe. The final method relies on one person using a draw, and the other a pry, on opposite sides of the canoe (see picture below). This is good for situations where the canoe needs to be moved sideways when there is not enough time for one paddler to switch sides, and a turn is impractical (i.e. dodging a rock in white water)